

4

3

2

1

REVISIONS				
ZONE	REV	DESCRIPTION	DATE	APPROVED

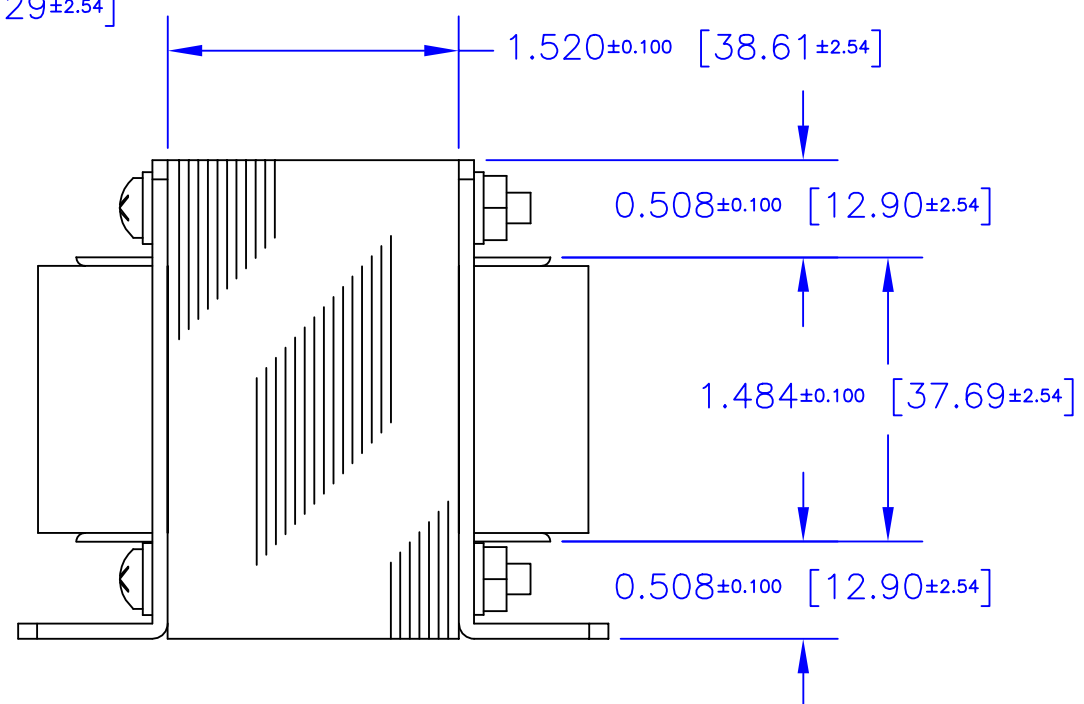
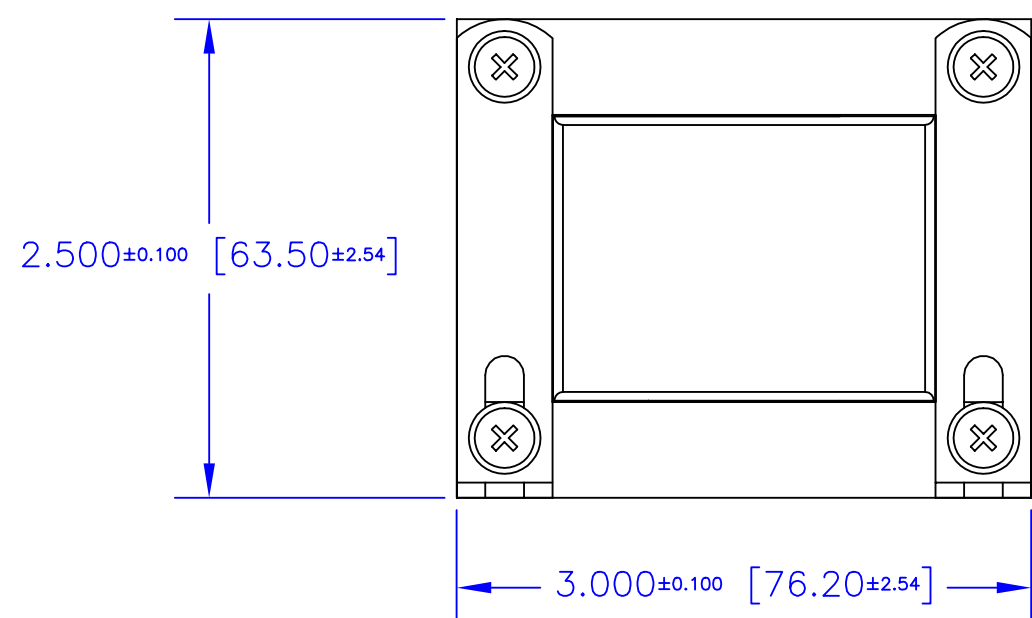
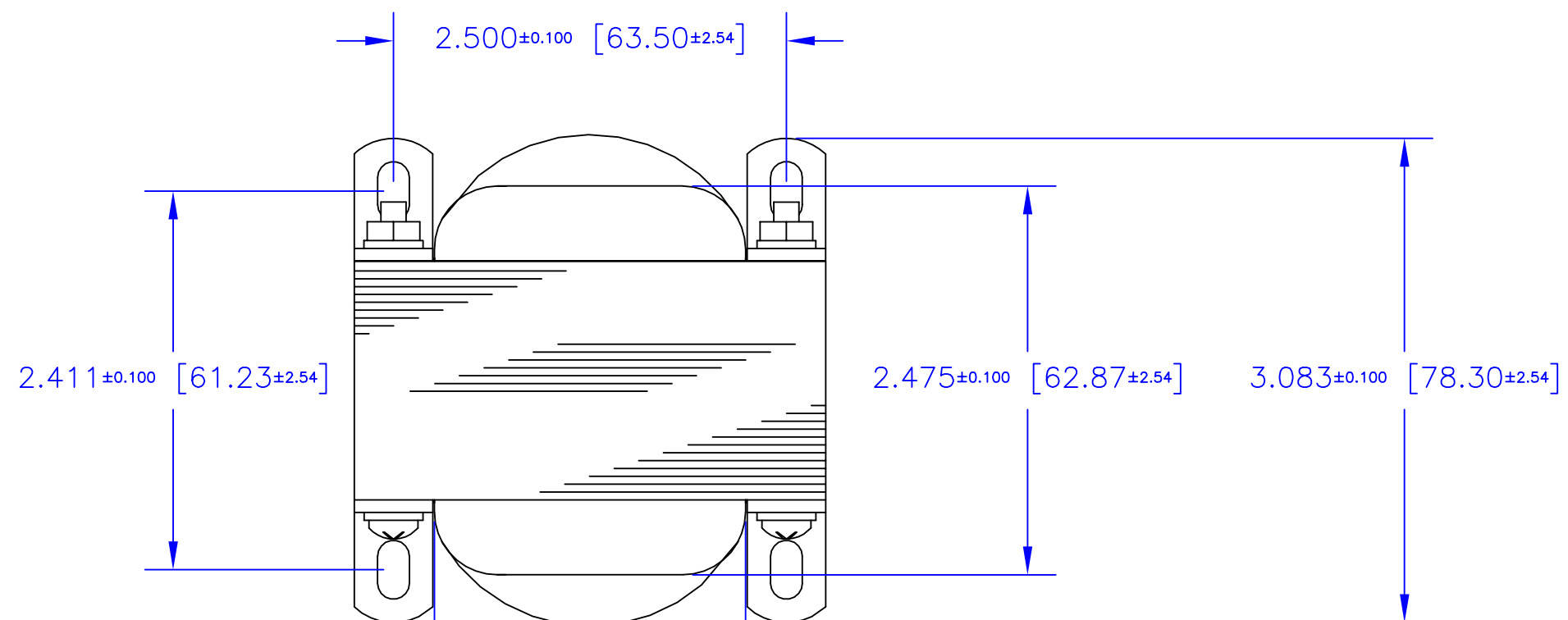

****NOTES: UNLESS OTHERWISE SPECIFIED!**
 1. ALL MATERIAL IS UL LISTED.
 2. BOBBIN IS AN EDCOR QUALITY SERIES.

DIMENSIONS ARE IN INCHES [MILLIMETERS]. X.XXX = ±0.010 X.XX = ±0.03 ANGLES = ±0.05 UNLESS OTHERWISE SPECIFIED		EDCOR Electronics 7130 National Parks Highway, Carlsbad, NM 88220 Voice: (505)887-6790 Fax: (505)887-6880 www.edcorusa.com		
DRAWING BY Brian Weston	Date 5/2004	EI100 x 1-1/2" bobbin. Audio Transformer.		REV
CHECKED BY Brian Weston	Date 5/2004	SIZE C	FSCM NO.	DWG NO. 15000-EI100-150-02
APPROVED BY Larry Weston	Date 5/2004	SCALE: 1:1	©2004 EDCOR Electronics	SHEET: 1 of 1

4

3

2

1